



ATTENZIONE: LA SICUREZZA DELL'APPARECCHIO E' GARANTITA SOLO CON L'USI APPROPRIATO DELLE SEGUENTI ISTRUZIONI. CONSERVARLE CON CURA.

Prima di eseguire qualsiasi tipo di operazione togliere la tensione di rete
Per la pulizia dei vetri si raccomanda di non usare mai abrasivi o solventi
Fare attenzione a non superare il Max di watt indicati per l'apparecchio
Mai coprire l'apparecchio durante l'impiego.

L'apparecchio deve essere equipaggiato con lampade autoprotette che non necessitano di schermo di protezione

Distanza minima tra lampada ed oggetti illuminati e tra lampada e parete/soffitto 0.5m

Max. potenza lampada 1x50W

Attacco lampada GU5.3

Tipo lampada  38°

Apparecchio classe III

Grado di protezione IP44 



ATTENTION: THE SAFETY OF THE APPLIANCE IS GUARANTEED ONLY IF IT IS PROPERLY USED, ACCORDING TO THE FOLLOWING INSTRUCTIONS, WHICH ARE TO BE KEPT.

Always disconnect the power supply before installing or performing any maintenance operations
For cleaning the glass do not use any abrasive or solvent materials
Make attention of not exceeding the maximum watt indicated on the appliance
Never cover the appliance while in function

The symbol mains the use of self-protection lamps which don't need of any protection screen

Minimum distance between bulb and lighted objects, between bulb and wall/ceiling 0.5m

Capacity of bulb 1x50W

Type of lampholder GU5.3

Type of bulb  38°

Appliance in class III

Protection class IP44 



ACHTUNG: DIE SICHERHEIT DIESES BELEUCHTUNGSKÖRPERS WIRD NUR DURCH DIE KORREKTE ANWENDUNG DER NACHSTEHENDEN ANWEISUNGEN GEWÄHRLEISTET. DIESE ÜSSEN DAHER SORGFÄLTIG AUFBEWAHRT WERDEN.

Bevor irgendwelche Arbeitsgänge ausgeführt werden, muß die Stromversorgung unterbrochen
Zur Reinigung der Gläser dürfen keine Scheuer- bzw. Lösungsmittel verwendet werden
Achten Sie darauf, daß die auf dem Beleuchtungskörper angegebene maximale Wattzahl nicht überschritten wird
Den Beleuchtungskörper während dem Betrieb nicht abdecken

Die Geräte dürfen ausschließlich nur mit selbstschützenden Leuchtmitteln benutzt werden, die keine Schutzgläser benötigen

Mindestabstand: Zwischen den Glühmitteln und dem Leuchtkörper / zwischen den Glühmitteln und der Wand/Decke 0.5m

Leistung der Gluehbirne 1x50W

Anschluss GU5.3

Typ der Gluehbirne  38°

Geraet der Klasse III

Schutzklasse IP44 



ВНИМАНИЕ: БЕЗОПАСНОСТЬ ОСВЕТИТЕЛЬНОГО ПРИБОРА ГАРАНТИРОВАНА ТОЛЬКО ПРИ УСЛОВИИ ЕГО ЭКСПЛУАТАЦИИ В СООТВЕТСТВИИ С ПРИВЕДЕННЫМИ НИЖЕ ИНСТРУКЦИЯМИ, КОТОРЫЕ НЕОБХОДИМО СОХРАНИТЬ.

Перед выполнением любой операции с осветительным прибором отключить напряжение в сети
Рекомендуется никогда не чистить стекло при употреблении абразивных веществ или Растворителей
Не превышать максимально допустимую мощность, указанную для данного осветительного прибора
Никогда не накрывать осветительный прибор в рабочем режиме

Рекомендуется снабжать осветительный прибор самозащищёнными лампами, не нуждающимися в защитного экрана

Минимальное расстояние: между лампочкой и освещёнными вещами, между лампочкой и стеной / потолком 0.5m

Максимальная мощность лампочки 1x50W

Тип цоколя лампочки GU5.3

Тип лампочки  38°

Осветительный прибор КЛАССА III

Класс защиты IP44 



ATTENTION: LA SÉCURITÉ DE CET APPAREIL N'EST GARANTIE QUE SI L'ON RESPECTE LES INSTRUCTIONS SUIVANTES. IL EST, PAR CONSÉQUENT, INDISPENSABLE DE LES CONSERVER SOIGNEUSEMENT.

Avant d'effectuer toute opération, débrancher la tension de réseau
Ne jamais utiliser des abrasifs ou des solvants pour le nettoyage des parties en verre
Veiller à ne pas dépasser la limite maximale des watts indiquée sur l'appareil
Ne jamais couvrir l'appareil pendant son fonctionnement

L'appareil doit être équipé avec ampoules masquées. écran de protection non nécessaire

Distance minime: entre ampoule et objets éclairés, entre ampoule et mur/plafond 0.5m

Puissance ampoule 1x50W

Culot GU5.3

Type ampoule  38°

Appareil de classe III

Classe de protection IP44 



ATENÇÃO: A SEGURANÇA DO APARELHO É GARANTIDA SOMENTE SE FOREM RESPEITADAS AS INSTRUÇÕES. PORTANTO, É NECESSÁRIO CONSERVÁ-LAS.

Antes de fazer qualquer tipo de operação, desligar a corrente eléctrica da rede
Para limpeza do vidro não usar materiais abrasivos ou solventes
Prestar atenção para não superar o número de watts indicados para o aparelho
Nunca cobrir o aparelho durante o funcionamento

Este símbolo significa o uso de lâmpadas protegidas, as quais não necessitam protecção adicional

Distância mínima: entre a lâmpada e o objeto iluminado, entre a lâmpada e o teto ou parede 0.5m

Potência máxima da lâmpada 1x50W

Tipo de suporte da lâmpada GU5.3

Tipo de lâmpada  38°

Aparelho de CLASSE III

Classe de protecção IP44 



ATENCIÓN: LA SEGURIDAD DEL APARATO ESTÁ GARANTIZADA SÓLO POR UN USO ADECUADO DE LAS SIGUIENTES INSTRUCCIONES; POR CONSIGUIENTE, ES PRECISO CONSERVARLAS.

Antes de llevar a cabo cualquier tipo de operación, desconectar la tensión de la red
Para limpiar el cristal no utilize ningún abrasivo o solvente
Prestar atención a no superar el máximo de los vatios indicados en el aparato
No cubrir jamás el aparato durante el funcionamiento

La lampara tiene que ser equipada con bombillas autoprotégidas que no necesitan de escudo de protección

Distancia mínima: entre bombilla y objetos encendidos, entre bombilla y pared/techo 0.5m

Potencia máxima de la bombilla 1x50W

Casquillo de la bombilla GU5.3

Tipo de bombilla  38°

Aparato CLASSE III

Clase de protección IP44 

- ① - Procedere al montaggio seguendo le operazioni in ordine numerico progressivo.
- ⒸⒺ - Proceed with assembling following the operations in progressive numerical order.
- Ⓓ - Arbeitsgänge in numerischer ordnung ausführen, um das gerät zu installieren.
- Ⓔ - Производите установку в порядке увеличения обозначенных выше номеров.
- Ⓕ - Il faut procéder a le montage exècutant les operatoins par l'ordre numerique progressif.
- Ⓖ - Proceder a montagem segundo as istruções em ordem numerica progressiva.
- Ⓔ - Proceder al montaje siguiendo las operaciones en orden numerico progresivo.

F19 F05 - F19 F24

DIMENSIONI-DIMENSIONS

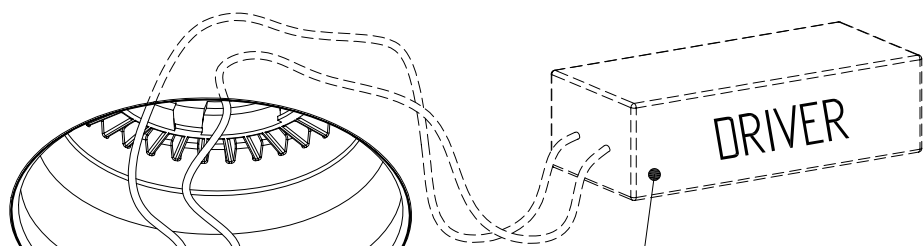
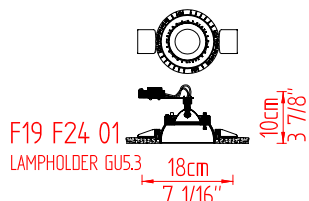
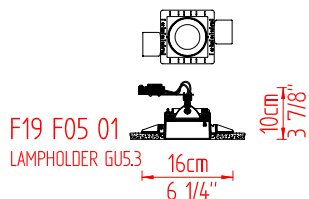

F19 F05/F24 - LAMPHOLDER GU5.3
cod. driver:
A22101 (max 1 spot)

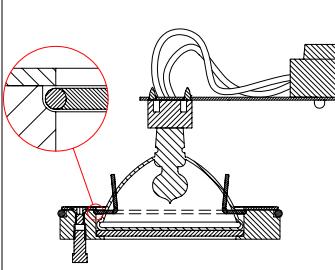
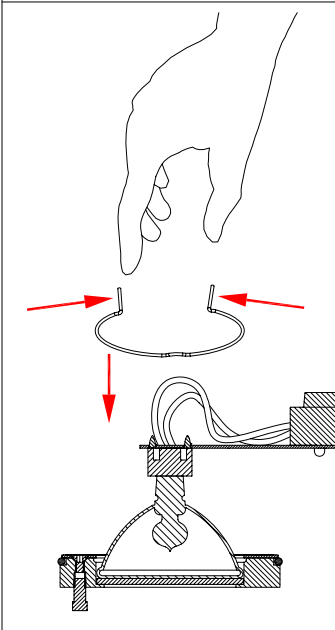
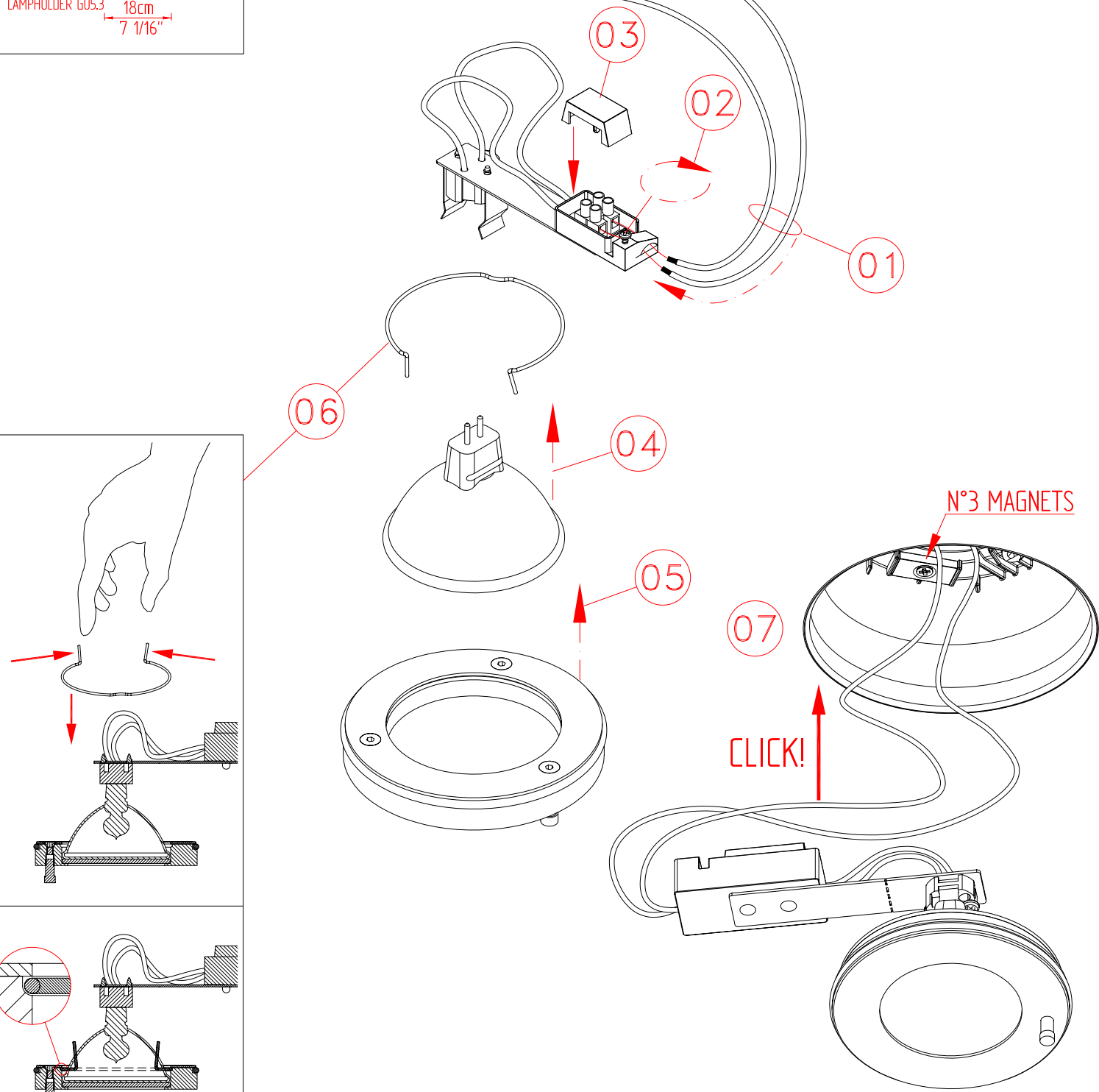

- ① - Procedere al montaggio seguendo le operazioni in ordine numerico progressivo.
- GB - Proceed with assembling following the operations in progressive numerical order.
- ④ - Arbeitsgänge in numerischer ordnung ausführen, um das gerät zu installieren.
- RU - Производите установку в порядке увеличения обозначенных выше номеров.
- F - Il faut procéder a le montage exècutant les operatoins par l'ordre numerique progressif.
- P - Proceder a montagem segundo as istruções em ordem numerica progressiva.
- ES - Proceder al montaje siguiendo las operaciones en orden numerico progresivo.

F19 Z01 - F19 Z02 F19 Z03

